

Feb. 20, 1923.

1,445,951.

S. O. HOFFMAN.
CIRCUIT CONTROLLING DEVICE.
FILED SEPT. 19, 1922.

2 SHEETS—SHEET 1.

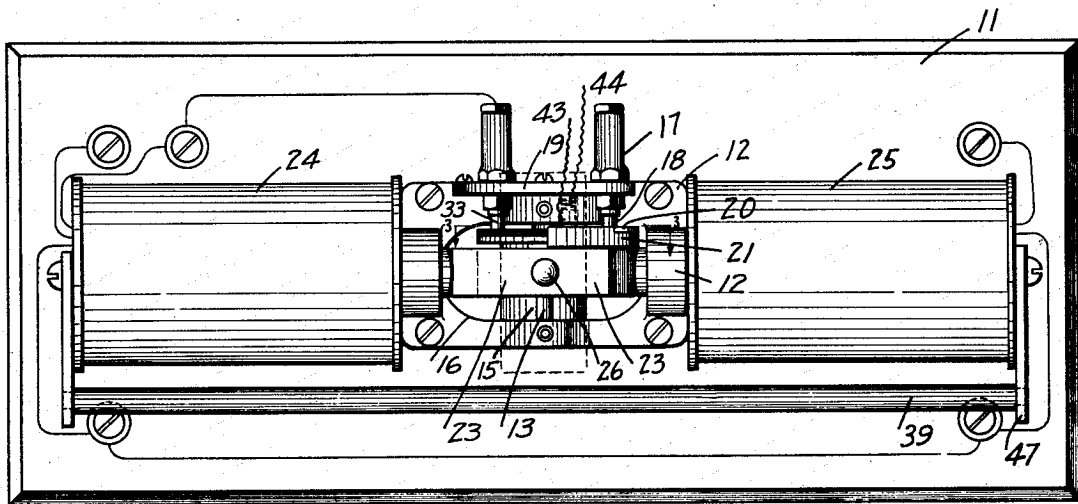

Fig 1

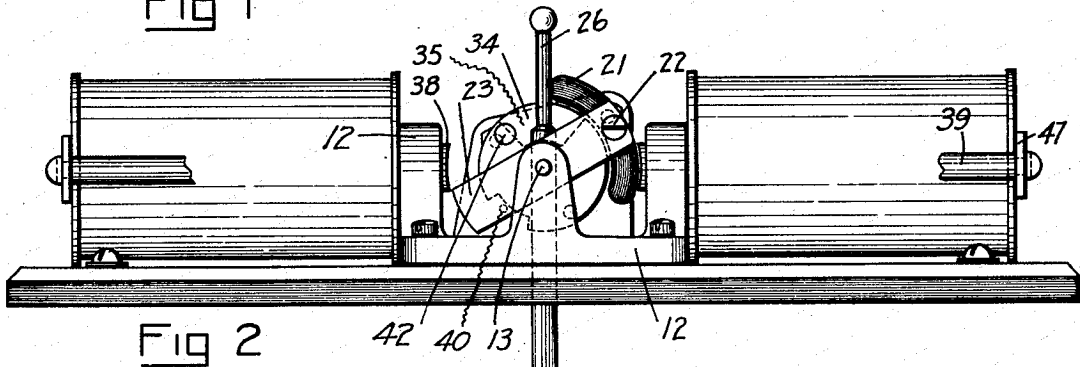

Fig 2

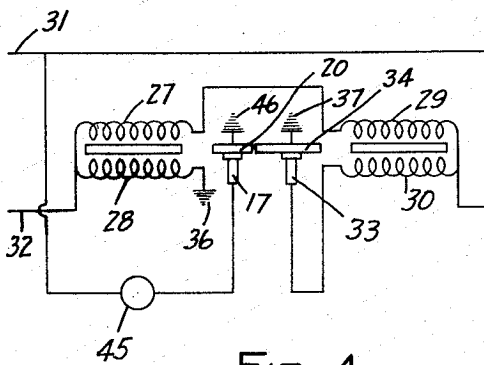

Fig 4

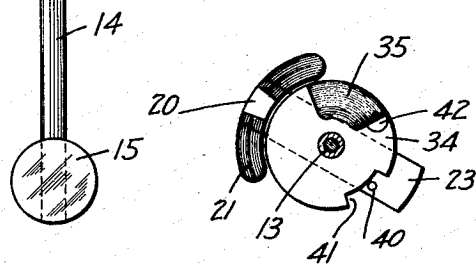

Fig 3

INVENTOR.
S. O. Hoffman
BY *White Frost & Co.*
ATTORNEYS.

Feb. 20, 1923.

1,445,951.

S. O. HOFFMAN.
CIRCUIT CONTROLLING DEVICE
FILED SEPT. 19, 1922.

2 SHEETS—SHEET 2.

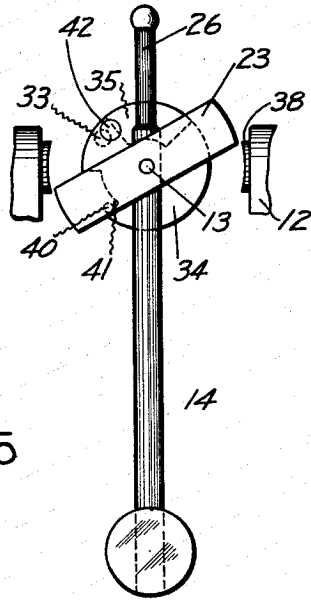

Fig 5

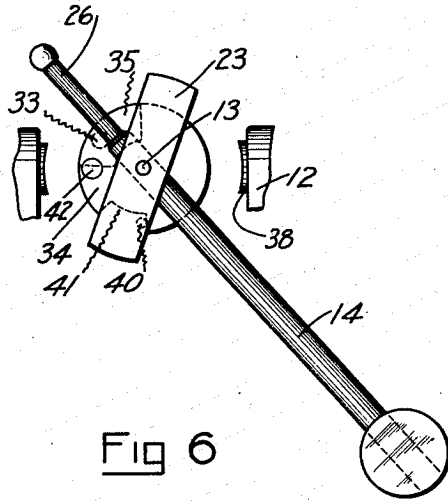

Fig 6

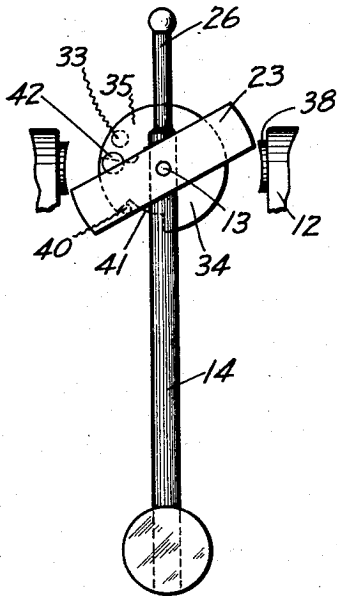

Fig 7

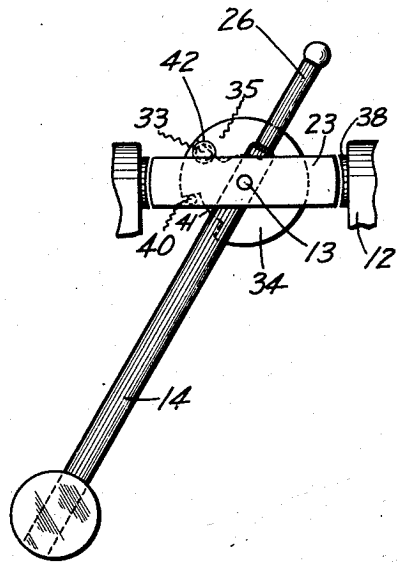

Fig 8

INVENTOR.
S. O. Hoffman
BY *White Post & Evans*
ATTORNEYS.

UNITED STATES PATENT OFFICE.

SAMUEL O. HOFFMAN, OF SAN FRANCISCO, CALIFORNIA.

CIRCUIT-CONTROLLING DEVICE.

Application filed September 19, 1922. Serial No. 589,110.

To all whom it may concern:

Be it known that I, SAMUEL O. HOFFMAN, a citizen of the United States, and a resident of the city and county of San Francisco, in the State of California, have invented a new and useful Circuit-Controlling Device, of which the following is a specification.

This invention relates to a device for making and breaking a contact periodically, in order to produce a pulsating E. M. F. Such a device may be used for example for obtaining electro-therapeutical effects, which may be produced by the periodic application of an electromotive force to certain parts of the human body. It has been found that the periodicity for good effects should be in the neighborhood of two hundred per minute.

Although it is possible to produce the making and breaking of the contacts to secure this result by the aid of a motor driven mechanism, such a construction has a high initial cost, and furthermore it is quite difficult to maintain the rate of making and breaking of the contacts constant within reasonable limits. It is thus one of the objects of my invention to produce a switching device that shall be simple and inexpensive, and that shall be capable of maintaining the rate constant within relatively narrow limits.

In order to accomplish these results satisfactorily, I utilize contacts adapted to be made and broken by the oscillations of a pendulum. It is thus another object of my invention to provide pendulum controlled contacts, with the advantage that the rate of making and breaking may be maintained substantially uniform. The power to keep the pendulum oscillating may conveniently be supplied with the aid of electromagnets.

My invention possesses other advantageous features, some of which with the foregoing will be set forth at length in the following description, where I shall outline in full that form of the invention which I have selected for illustration in the drawings accompanying and forming part of the present specification. Although in the drawings I show but one embodiment of my invention, it is to be understood that I do not desire to be limited thereto, since the invention as expressed in the claims may be embodied in other forms also.

Referring to the drawings:

Figure 1 is a top plan view of a mechanism embodying my invention;

Fig. 2 is a side view of the same;

Fig. 3 is a sectional view taken along line 3-3 of Fig. 1;

Fig. 4 is a wiring diagram of the device; and

Figs. 5, 6, 7 and 8 are diagrams illustrating the various phases of operation.

A base 11 of insulating material may be provided, upon which is supported the operating parts of the device. A supporting bracket 12 appropriately secured to the base 11 serves as a bearing for an oscillating shaft 13. To this shaft is secured an oscillating member, such as the pendulum 14, having a weight 15 shown as cylindrical in form, attached at its free end. The base 11 may be appropriately apertured as at 16 in order to permit the pendulum or other oscillating member to extend below the base.

An oscillating member such as a pendulum has a period which is a function of its physical characteristics; under all ordinary conditions of operation, this period is maintained substantially uniform. In order to utilize these free oscillations to produce a pulsatory E. M. F., a stationary contact stud 17 having a contact 18 is supported on an insulating slab 19 which is fastened to the support 12. The contact 18 cooperates with a contact segment 20 which is arranged to be movable with the pendulum 14. For convenience this segment 20 is supported in a groove on an insulating arcuate member 21, which in turn is fastened as by screw 22 to an armature 23 of magnetic material. This armature is fastened to the oscillating shaft 13, and is used in connection with electromagnets 24 and 25 to keep the pendulum oscillating. The armature 23 is of symmetrical form, its center of symmetry coinciding with the center of oscillation. As thus far described, it is evident that as the pendulum 14 describes a complete oscillation, the contact segment 20 sweeps past the stationary contact 18 twice; once when the pendulum swings to the right and again when it swings back to the left. In order to start the oscillation of the pendulum, I provide a projection 26 which may be manually moved whenever the device is started.

To keep the pendulum 14 oscillating after it is once started, the electromagnets 24

65

70

75

80

85

90

95

100

105

110

and 25 are made to exert a force on armature 23 periodically in synchronism with the oscillations of pendulum 14. Each electromagnet is provided with two coils 27, 28 and 29, 30. The coils 27 and 28 have equal and opposed magnetomotive forces when energized, and this is also true of coils 29 and 30. The net result is that when all coils are energized, there is no force acting on armature 23. However, a switching arrangement is provided for deenergizing one of the two coils on each electromagnet. In the present instance the coils 27 and 29 are continually energized and are connected in series across the lines 31 and 32. The circuit for the other two coils 28 and 30 is controlled by a pair of contacts 33 and 34. The contact 33 is supported on the insulating slab 19, while contact 34 is in the form of a disc mounted for rotation on shaft 13 and moved in response to the movement of pendulum 14. A portion of the disc is cut away for the accommodation of thesegmental insulation piece 35, as shown most clearly in Fig. 3. As this piece 35 moves under the stationary contact 33, the arrangement is such that the circuit for coils 28 and 30 is interrupted. With the aid of the wiring diagram of Fig. 4 this action may be readily explained. One of the coils, such as 28, is connected to one of the mains 32, and its other end is grounded at 36 on the mechanism. The contact disc 34 is shown also as grounded at 37, and when it is contacting with the member 33, the coil 30 is in series with coil 28. The other terminal of this coil is connected to the other main 31. When the connections are thus completed, the magnetic fluxes are completely neutralized, and there is no magnetic force acting on the armature 23. In order that there be substantially zero magnetomotive force, I wind coils 27, 28, 29 and 30 with exactly the same number of turns and also of the same resistance so that they all carry the same current. I preferably wind one of the coils of each set 24, 25 over the other, and therefore to maintain the resistance equal, the outer coil, using a greater length of wire, is wound with heavier wire.

The magnetic circuit for the electromagnet 24 comprises the core 38 which is held in the support 12 and has an arcuate face opposed to the armature 23. The remainder of the magnetic circuit includes one end of the armature 23 an air gap, and a portion of the bar 39 of magnetic material. This bar extends between the ears 47 attached to the cores. Each electromagnet thus has its own magnetic circuit.

The mechanical connection between the contact disc 34 and the pendulum 14 includes a pin 40 carried by the armature 23 and arranged to coact with the sides of the slot 41 in the disc 34. The slot provides

for some play between the pin 40 and disc 34, so that there is lost motion between them. In this way the pendulum 14 is allowed to swing a considerable distance out of the influence of the electromagnets before they are energized, and is not influenced by them until it has swung backward again. To understand this action thoroughly, it may be advisable to trace through the various phases of the pendulum oscillation. If the pendulum be swung to the right of the position shown in Fig. 2 to start the oscillations, the armature 23 will be moved farther out of the influence of the magnets. The pin 40 acts at the same time to move contact disc 34 out of contact with the stationary stud 33, soon after the central position of the pendulum is passed, and therefore the magnets are energized, since the coils 28, 30 are open-circuited and coils 27 and 29 are active. This condition is shown in Fig. 6. The energization of the coils has little effect, however, upon the return of the pendulum, since in this extreme right hand position of the pendulum the armature 23 is out of the influence of the field. However, gravity alone is sufficient to swing the armature into the field. This position corresponds to mid-position of the pendulum illustrated in Fig. 7 and it is here that the magnetic impulse is given it. Due to the slot and pin connection between the pendulum and disc, the magnets remain energized even after the pendulum reaches the central position of this figure. Shortly after the pendulum leaves this central position, the disc 34 contacts with contact 33, and the magnets become ineffective. Gravity carries the pendulum to its extreme left hand position, as shown in Fig. 8. When it swings back toward the right again, contact between members 33 and 34 is broken near the central position, so that here again a small magnetic impulse is imparted to the pendulum. This position corresponds to one slightly beyond that of Fig. 5. This impulse continues only until the armature swings out of its central position, as described hereinbefore in connection with Fig. 6.

The operating current flowing through coils 27, 29 and 28, 30 is appreciable and in order to prevent sparking between the contacts 33, 34, I preferably use silver for contact 33, and provide a small silver inset 42 in the disc 34 of substantially semicircular shape. This member 42 is so located that when contact is broken, it is accomplished between this member 42 and contact 33. Sparking is maintained at a minimum due to the fact that the circuit is broken when there is least magnetic interlinkage, the magnetic effects of the coils reducing to zero. In order that the disc 34 be held in any of its positions without danger of moving except when engaged by the pin 40, I

employ a plunger 43 pressed by spring 44 against the disc 34. Thus a small frictional holding force is always opposed to the free movement of the disc.

5 The making and breaking of the contact between members 17 and 20 may be utilized in any well-known manner to produce therapeutic effects. In most instances it is merely necessary to connect one or the other
10 of these members to a source of potential, and apply the other terminal directly or indirectly to the human body. In many cases this other terminal is connected to one terminal of an inductance coil, the other terminal of which is left unconnected. In
15 this way a charging current of very minute proportions is intermittently fed to the coil. During periods of disconnection the charge leaks off to some extent, so that each making of the contact produces some flow of
20 current. A secondary may be connected to the inductance coil in order to increase the voltage, and the terminals of this secondary may then be applied to the body. I have
25 considered it unnecessary to show these various elements in the diagram of Fig. 4, where instead I show some form of translating device or load 45, the circuit of which is intermittently completed between 20, 17. For
30 this purpose the contact 20 is grounded, as at 46, so that the voltage impressed upon the load 45 is substantially that across one of the coils 28, 30. The shunting of one of the coils by this load as shown in the wiring
35 has no appreciable effect on the operation of the device, since the current through the load is never of the same order of magnitude as that through the coils.

I claim:

40 1. In a device for producing a pulsatory electromotive force of substantially uniform rate, a free oscillatory member, contacts for producing the pulsations, operated in response to the oscillations of the member,
45 an electromagnet, and means whereby the magnet may exert an intermittent periodic force on the oscillatory member, comprising a stationary contact, a movable contact, and a lost motion connection between
50 the oscillatory member and the movable contact, of such character that the contacts are in proper cooperative relation to cause the electromagnet to act with a substantial force on the oscillatory member for
55 swinging this member through its central position in one direction, after which the magnet is inactive, and due to the lost motion connection, is energized during the reverse swing only after the oscillatory member has passed a considerable distance away
60 from the influence of the magnet.

2. In a device for producing a pulsatory electromotive force of substantially uniform rate, a free oscillatory member having considerable inertia, contacts for producing the

pulsations operated in response to the oscillations of the member, a substantially symmetrical armature fixed to said member so as to be oscillated thereby, the center of oscillation coinciding substantially with the
70 center of symmetry of the armature, an electromagnet having a core with a gap arranged so as to be bridged by the armature during a portion of its oscillation, and means for periodically energizing said magnet so that
75 it may exert a force on the armature, comprising a stationary contact, a contact mounted for oscillation about the center of movement of the armature, and a lost motion connection between one of the oscillating
80 members and said contact.

3. In a device for producing a pulsatory electromotive force of substantially uniform rate, a free oscillatory member having considerable inertia, contacts for producing the
85 pulsations operated in response to the oscillations of the member, a substantially symmetrical armature fixed to said member so as to be oscillated thereby, the center of oscillation coinciding substantially with the
90 center of symmetry of the armature, an electromagnet having a core with a gap arranged so as to be bridged by the armature during a portion of its oscillation, and means for periodically energizing said magnet so that it may exert a force on the
95 armature, comprising a stationary contact, a contact disc rotatable about the axis of oscillation, said disc having a slotted portion, and a pin attached to one of the oscillating members and projecting into the
100 slot, whereby a lost motion connection is produced between the disc and the oscillating members.

4. In a device for producing oscillatory
105 motion, a free oscillatory member having considerable inertia, an electromagnet, and means whereby the magnet may exert an intermittent periodic force on the oscillatory member, comprising a stationary contact,
110 a movable contact, and a lost motion connection between the oscillatory member and the movable contact, whereby the contacts cooperate to energize the magnet for swinging the oscillatory member through its central
115 position in one direction, after which the contacts de-energize the magnet, and upon the reverse swing, the magnet becomes energized only after the oscillatory member is moved a considerable distance away
120 from the influence of the magnet.

5. In a circuit controlling device, an oscillating member, and means for maintaining the oscillations comprising a pair of
125 equal magnetomotive force, and means for interrupting the circuit of one of said coils synchronously with the oscillations of the member at a point near the central position of the member.

6. In a device for producing oscillatory motion, an oscillatory member having considerable inertia, and means for oscillating said member, comprising an armature fixed to the member, an electromagnet for influencing the armature periodically, having a pair of differentially wound coils of substantially equal magnetomotive force, and means for periodically interrupting the circuit of one of said coils in response to the movement of the armature.

7. In a device for producing oscillatory motion, an oscillatory member having con-

siderable inertia, and means for oscillating said member, comprising an electromagnet having a pair of differentially wound coils of substantially equal magnetomotive force, a core for said magnet, an armature fixed to the oscillatory member and arranged to sweep past the face of the core, and means for periodically interrupting the circuit of one of said coils in response to the movement of the armature past the magnet.

In testimony whereof, I have hereunto set my hand.

SAMUEL O. HOFFMAN.